

Glass Recycling Line

Throughput roughly ca. 1,5+ t/h

The line can be used also for wood, plastic and the waste, if set so.

Glass Recycling Line (200 working hours, Year 2015)

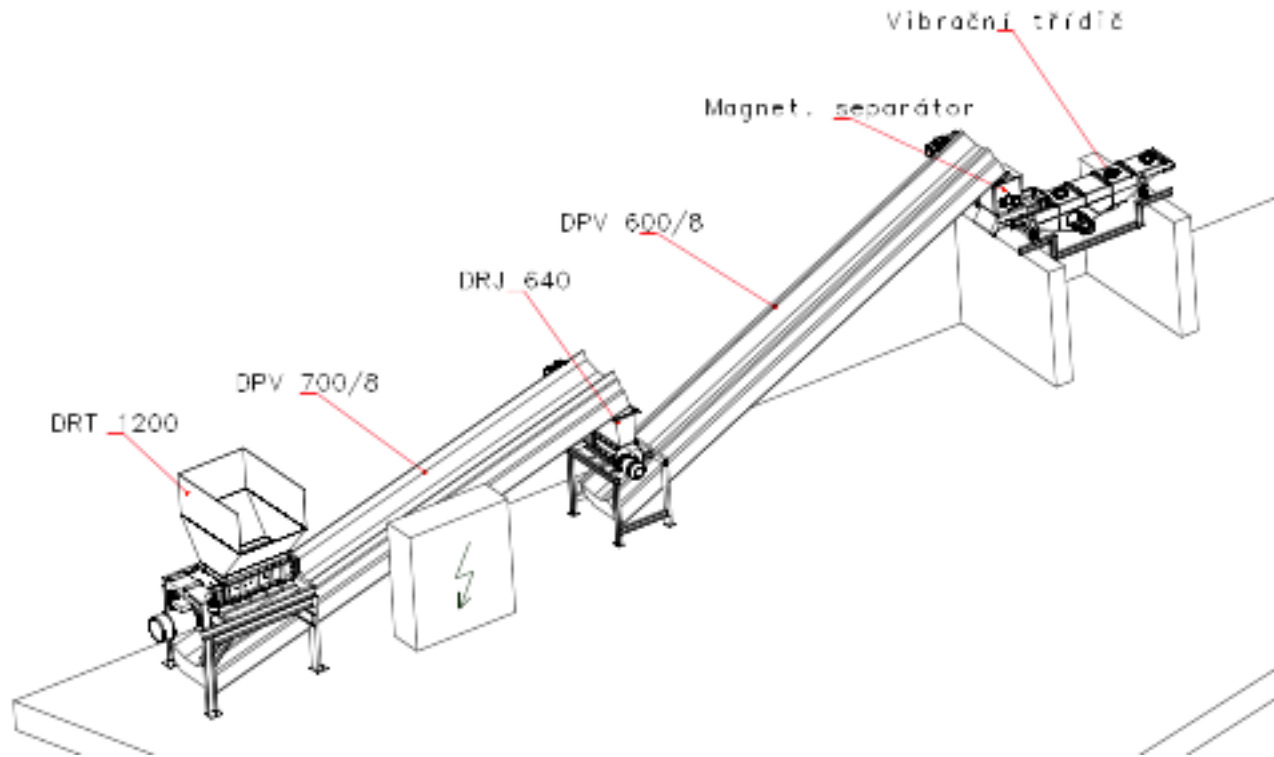

Parts of the line:

1/ Primary Shredder DRT 1200/30 kW

2/ Conveyor DPV 700/8

3/ 2x Secondary Shredder DRJ 64/9,2 kW (1 Shredder added afterwards)

4/ Conveyor DPV 600/9,5

5/ Magnetic Separator Fe - MSP 204/400

6/ Size sorting equipment VBT 300-2400

7/ Dust aspirator FT 200 SF

8/ PLC + Cabinet

Glass Recycling Line – adaptable on other materials



Glass Recycling Line – adaptable on other materials



Glass Recycling Line – adaptable on other materials



Glass Recycling Line – input & outputs

